

On Design of Negative Impedance Converter at Microwave Frequency

Mehmet Suvar Parlak

Mohammad Hossein Nemati

Abstract— In this work we have studied the viability of designing Negative Impedance Converter (NIC) at microwave frequency say around 2GHz. surfing on open literature, 1.5GHz is the highest frequency in which NIC design has been reported to date. There is a simple reason behind this: in microwave frequency, the length of transmission line becomes significant and make great phase shift. For example, at 2GHz 1mm TL on FR4 substrate makes 4° of phase shift and this while for soldering we at least need 3mm space!. Moreover, presence of parasitic element in transistor model at higher frequency and stability problem also hinder design of NIC at microwave frequency. Reducing the parasitic effect of transistor and using MMIC technology can solve the above problems with NIC design. To verify the concept, a 2GHz NIC circuit designed and studied. However, one NIC circuit has been design and constructed around 20MHz.

I. INTRODUCTION

The impedance of an electrically-small antenna is highly reactive. In other word, electrically-small antennas, regardless of their shape and type, have high Q, and consequently are difficult to match with passive circuitry [1]. However, it is possible to match a small antenna using a Non-Foster matching circuit. Non-Foster impedance matching is defined as the use of negative inductors and negative capacitors to manage the transfer of power between a source and a load. It is the negative impedance converter (NIC), discovered over 50 years ago, which creates negative elements by transforming conventional passive L's and C's into their negative counterparts. For a lossless one-port with positive elements and whose driving-point impedance is given by $Z(j\omega) = R(\omega) + jX(\omega)$, Foster's reactance theorem says that the slope $dX/d\omega$ must be positive. With negative elements this slope can become negative, hence we apply the appellation "non-Foster" to networks containing negative reactive elements [2]. There are a lot of NIC circuit topologies in literature but small number of them have been built and tested. The topology used in this project is that of Linvill transistor pairs, as shown in Fig.1.

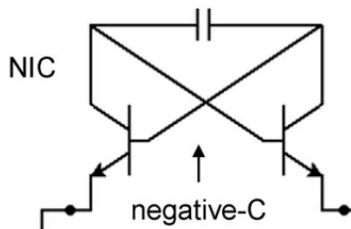

Fig.1: NIC circuit topology

In this report, we first study design of a NIC circuit for 2GHz and describe why it is not possible to match dipole antenna in this frequency range. then design of a NIC circuit has been reported for 20MHz using above topology.

II. NIC CIRCUIT VERIFICATION AT 2GHz:

Before starting NIC design we need to have knowledge about Monopole input impedance. For this, a monopole antenna designed in HFSS. Fig.2 shows Monopole antenna's input impedance together with designed NIC input impedance. As it is evident in Fig.2, impedance is of capacitive nature with small real part.

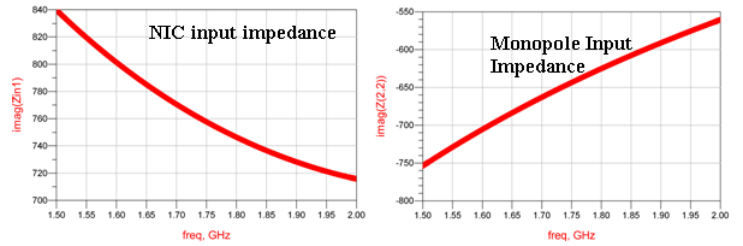

Fig.2: Monopole input impedance together with designed NIC input impedance

Based on conventional methods, a NIC circuit has been designed and simulated in ADS. Fig.3 shows the schematic of ADS design.

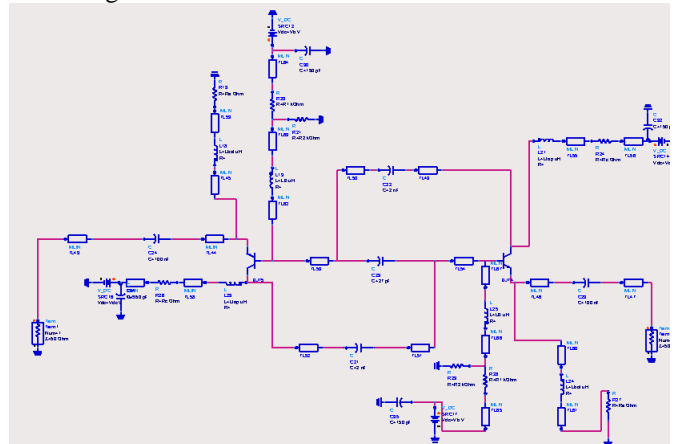

Fig.3: designed NIC circuit and input impedance

Fig.2 shows the input impedance of designed circuit. It would be more intuitive if we look at the NIC input impedance on Smith chart. below is the Smit chart representation of input impedance.

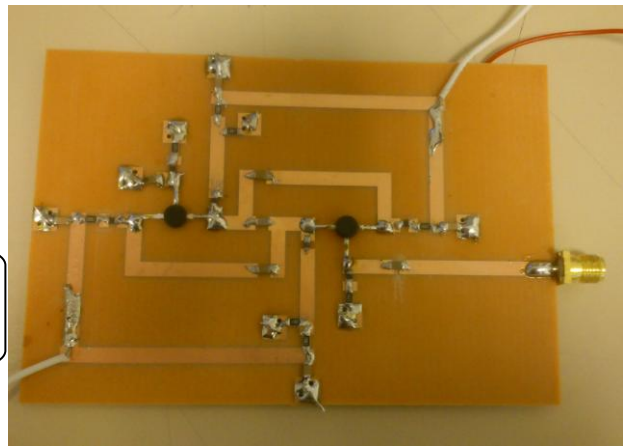
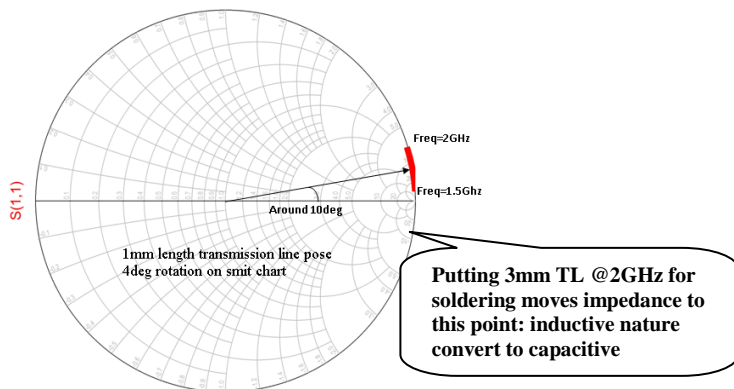
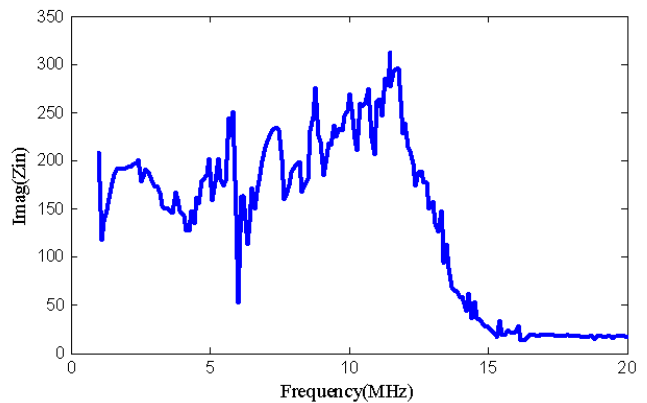

Fig.5: Constructed NIC

The measured input impedance is as below:



III. NIC DESIGN AT 20MHZ:

To see the practical response of NIC circuit, a NIC circuit designed and tested. Simulation result shows negative impedance behavior between 3-20MHZ.

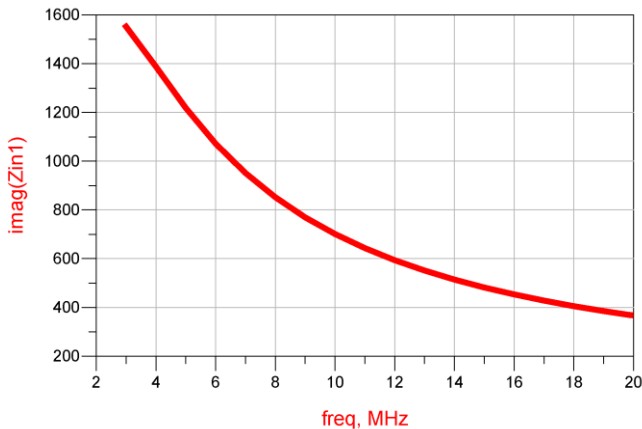

Below is the picture of constructed NIC:

IV. CONCLUSION:

One of the main drawbacks when designing microwave antennas with small size is its inherent low bandwidth and not very good efficiency. An attempt to overcome this problem is based on using negative impedance converters (NICs). Although the use of NICs have been proposed as a solution to increase the bandwidth of electrically small antennas, they suffer from many problems such as stability performance, bias and the maximum frequency that can be achieved. So, the application of NICs has been restricted to low frequency applications in order to avoid the previous problems. Taking advantages of MMIC design technology make it possible to design NIC at microwave frequency.

References

- [1] S. E. Sussman-Fort, R.M. Rudish, " Non-Foster Impedance Matching of Electrically-Small Antennas," IEEE transaction on antenna an propagation, Vol. 57, NO. 8, 2009.
- [2] S. E. Sussman-Fort, R.M. Rudish, "Non-Foster Impedance Matching for Transmit Applications".